

PRESS MOUNTING

Bolt your press to a solid bench. Use 1/4" nuts and bolts of suitable length. (Available at all hardware stores, 3 each required.) For convenience, a 1/2" hole may be drilled through the workbench to permit spent primers to pass through. This hole may be located any place under the base of your press. Attach the lever to point up when the ram is down.

AUTO-DISK POWDER MEASURE

The Lee Pro Auto-Disk Powder Measure is an improved version with a positive pull back.

The bottom end of the chain should pass through the hole in the carrier. Attach the brass pendant to the chain so the measure is fully retracted when the ram is in the extreme down position. Some chain should dangle below the pendant as the weight helps the chain slide through the carrier hole on each cycle. Fine adjustment is easiest done where the chain attaches to the powder measure. The chain passes through two holes in the lever and it will never move, yet it is easily adjusted. Store the connecting link on the end of the chain. It will be available should you need it for a repair.

Install the proper disk into the Auto-Disk Powder Measure. See Auto-Disk Powder Measure Instruction Sheet for details. Select load from data supplied with your Lee Dies of from any reliable source. Fill the hopper with the correct powder.



SETTING UP

Slip the turret into the press with the sizing die (the one with the decapping pin) up front. The dies have been factory adjusted, but will require bullet depth adjustment, minor crimp adjustment and minor flare adjustment. See Die Instruction Sheet for details.

FILL THE PRIMER TRAY

WARNING: Use only CCI or Winchester brand primers. Other brands, especially Federal, can explode with sufficient force to seriously injure the user or persons nearby.

ALL PRIMERS ARE DANGEROUS and it should be anticipated that the primers in the tray could explode through accident, misuse or spontaneously. Should an explosion occur, our tests have demonstrated that safety glasses will normally prevent serious injury to the user if CCI or Winchester primers are used, because the explosion is minimal. Other primers, however, can explode with sufficient force to seriously injure the user, or persons nearby. We do not take any position with respect to the quality of performance of primers available on the market. However, **ONLY** those primers manufactured by CCI or Winchester are recommended for use in the Lee Pro 1000—and when loading those primers—safety glasses must be used. **NO OTHER PRIMERS** should be used with the Lee Pro1000.

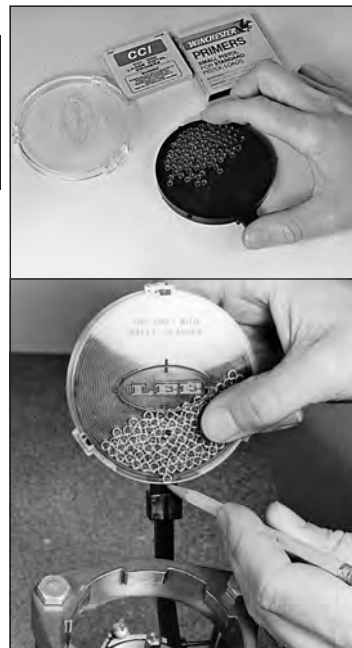

Place no more than 100 CCI or Winchester brand primers in the tray. (Use of any other brand exposes the operator to unnecessary risks.) With the cover off, shake side to side to turn all primers right side up.

With the cover on, use a pencil to hold the primers in the tray while assembling it to the priming tool. Shake the unit side to side to fill the primer trough

LOADING A SINGLE CASE

Start with the lever in the down position (shell plate carrier up). Always move the lever to a full stop.

- Place an empty case in front of the case slider. Slowly raise the lever and the case slider will push the case into the shell plate. Slowly lower the lever to size and deprime the case.
- Raise the lever—the case will be indexed to the next position and be primed at the bottom of the stroke. **IMPORTANT: The primer is seated during the last inch of lever travel. Make a conscious effort to feel the primer enter and fully seat into the case. Incomplete primer seating will not permit the case to eject from the shell plate. This seems to be the biggest problem for first time users.**



- Lower the lever, and the powder measure will automatically charge the case while expanding the case mouth to accept the bullet

Raise the lever and the case will be positioned under the bullet seating die. Start a bullet into the case, then lower the lever to seat the bullet and crimp it in place. If you are unable to start the bullet into the case mouth because of insufficient flare, screw the expanding die (the die with the powder measure) 1/4 turn deeper. If the bullet is not seated to the proper depth, turn the bullet seating adjusting screw in or out to suit. Crimp is increased by screwing the entire bullet seating die deeper. Make crimp adjustments no more than 1/4 turn. See Die Instruction Sheet for details.

CAUTION: The rear two dies should never be adjusted so deep that they contact the shell plate. Serious damage to the carrier can occur.

Raising the lever causes the shell plate to rotate and eject the loaded round into the chute. This completes one cycle.

The most important thing to remember is that once you start moving the lever in a direction, do not reverse directions until it comes to a complete stop at the end of the stroke — **making sure that the primer is fully seated on the lever upstroke.**

The hazards of not doing this are: [A] a double charge at the top of stroke. [B] the shell plate will get out of time. (Should the shell plate get out of time, disengage the ratchet by raising the shell plate carrier 1/4" and advance the shell plate by hand.)

Continue loading one case at a time until you are satisfied all is in order.

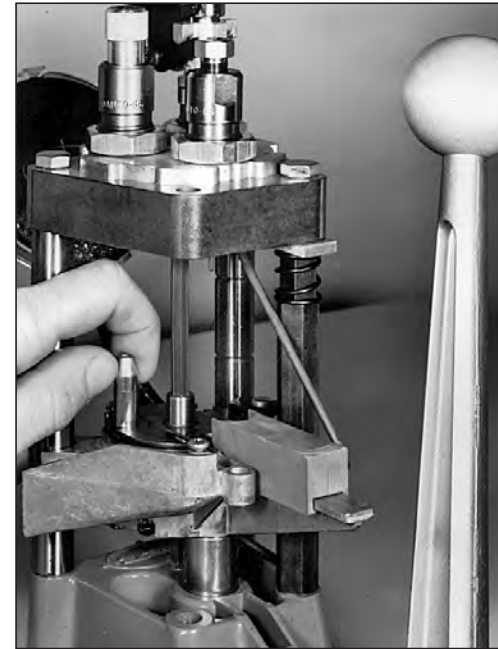

YOU ARE NOW READY TO START PROGRESSIVE RELOADING

WITHOUT THE CASE FEEDER

At the bottom of each lever stroke, place a case in front of the case slider. At the top of each lever stroke, start a bullet into the case.

- [A] Always slowly move the lever to the positive stop.
- [B] Priming is done on the lever upstroke. Learn to feel the primer being seated. **Be sure to raise the lever completely to fully seat the primer.**
- [C] Powder is automatically dispensed at the bottom of each stroke. **After the powder has been added, it is imperative that the lever be fully raised to index the case from under the charging die. A short stroke will cause a double charge.**
- [D] Anytime the press tends to bind — **STOP!** Determine the reason for the binding and correct the problem. Do not force it or something will be damaged.

ATTACH THE CASE FEEDER

Position the case feeder assembly to just clear the turret ring and almost the thickness of a dime above a cartridge case.

Slip the four tubes into the case feeder and fill them with cases, head down.

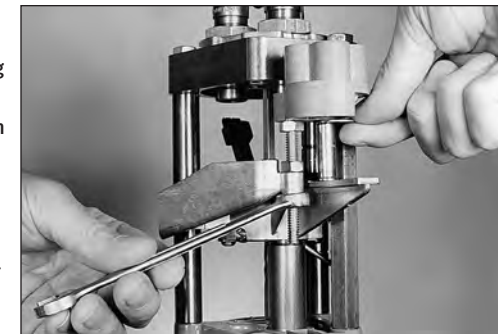

OPERATING INSTRUCTIONS

- Do not run out of primers or powder. It is easy to forget because you will be turning out ammunition much faster than you are accustomed to. What used to be an evening's reloading is now accomplished in a few minutes.
- Always move the lever smoothly through its full travel. A short stroke can cause a jam or double charge.
- Do not force it or you will break something. If it does not feel right, stop and check out the problem.
- Keep the primer trough full. Running out of primers will cause a jam.
- Polish the chute with steel wool and lightly oil or wax to help loaded rounds slide into your container.

SAFETY CONSIDERATIONS

- Never place more than 100 primers in the tray.
- Use only Winchester or CCI primers. Other brands, especially Federal brand, can explode with sufficient force to seriously injure the user or persons nearby.
- Be sure of proper powder and charge for bullet weight selected.
- Wear safety glasses when reloading or shooting.
- Be extremely careful to avoid a double charge. If in doubt, empty the case and recycle it.
- Do not permit distractions while loading. This is a complex machine that needs your fullest attention.
- Do not increase the capacity of the powder hopper. More powder is many times more hazardous.
- Oil all moving metal parts every few thousand rounds or before use if the press has been idle two weeks or more. Use 20 wt. motor oil or equivalent.

WHEN THINGS GO WRONG

Problems are usually caused by operator error. However, the Lee 1000 is the easiest of all progressive presses to straighten out. The cases can be removed from each station; rotate the shell plate a few degrees by hand—the case can then be pulled out without damage to the spring fingers. If a partially seated primer holds the case in the shell plate, rotate the plate to the slot on the left edge and lift the case out.

The most important hazard to guard against is a double charge. It is always best to completely remove the offending case, dump the powder into the hopper and the case into the case feeder if the primer is not protruding.

After removing the offending case, continue loading. There is no need to have a case in each position.

PROBLEM	CAUSE	REMEDY
Primers not fully seated	Operator not pushing hard enough	Learn to feel the primer seating when the lever is pushed up.
	Shell plate carrier not fully seated, or loose on ram	Loosen allen screw and force shell plate carrier on the ram. Retighten allen screw.
	Obstruction to full travel	Check for primer on base or under shell plate carrier. Carrier should contact the base with no case in the shell holder.
Primer doesn't feed onto priming punch	Oil in trough	Remove all oil with solvent.
	Case sensor detached	Reattach case sensor to sensor clip.
	Primer trough not full	Always keep primer trough full.
Primer doesn't enter case	Primer crimp not removed	Ream or swage primer pocket.
Tipped primers	Case not fully in shell holder	Clean shell holder. Check tension finger. Straighten or replace tension finger as required.
	Improper index adjustment	Adjust index. See "Zero Adjustment" on page 6.
Cases don't eject	Primers not fully seated	See "Primers not fully seated" problem above.
	Cases wedge against ejector pin	Move ejector pin to other side of screw.
Jerky case feeding	Occurs with 45 ACP conversions because Z-bar hits case feeder	Bend Z-bar down 1/8" in center to clear case feeder. Factory fitted presses have this bend.
Case feeder doesn't work properly	Wrong case feeder	Be sure you're using the correct case feeder for the caliber you're loading. (See page 6 for proper combination.)
	Z-bar in wrong case slider hole	Use hole closest to screw.
Z-Bar slips out of case slide	Z-bar attachment not straight	Loosen right front column bolt and swing the Z-bar attachment as needed to hold a slight inward pressure. The short end of Z-bar should enter the case slider.
Case doesn't enter shell plate	Improper index adjustment	Adjust index. See "Zero Adjustment" on page 6.
	Case slider binding	Repair damage to slider rail with file.
Shell plate turns halfway	User damaged drive bolt	Replace drive bolt. Order TR243I Drive Bolt.

CHANGING THE SHELL PLATE CARRIER

- 1 Remove turret, primer tray and z-bar
- 2 Loosen allen screw clamp
- 3 Place wood block under carrier
- 4 Use lever to pull ram out of carrier

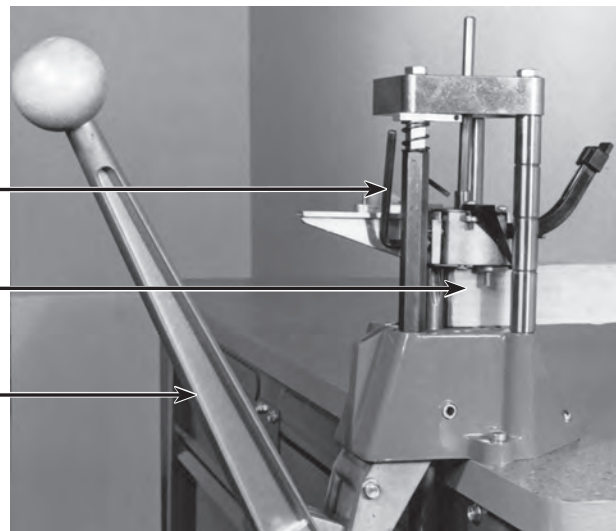

INSTALLING THE SHELL PLATE CARRIER

The carrier is attached to the ram with a single socket head screw. This makes it very easy to change the entire carrier for caliber changing.

- 1 Push the action rod through the carrier from the bottom side until the end slightly protrudes through the top. Be sure the twisted end is down.

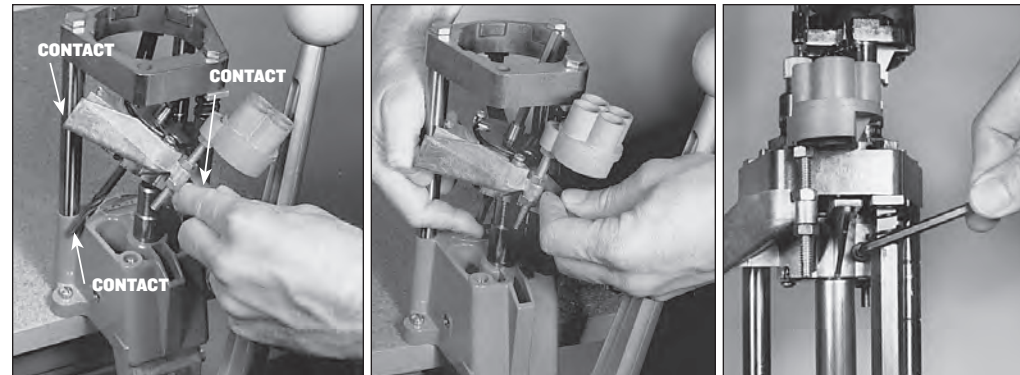

- 2 Insert the assembly from the front of the press until it contacts the press in three places as shown.
- 3 Push the action rod up through the top of the press and continue rotation to level position. Be sure to keep the primer trough pin behind the right rear column.
- 4 Push the assembly onto the ram's end. Tighten the clamp screw with a hex wrench. **DO NOT OVERTIGHTEN.**

CHANGING SHELL PLATE ONLY

- 1 With the shell holder carrier free of the press, loosen the screw that holds the ejector and remove the ejector. **DO NOT LOSE IT!**
- 2 Using a 1/4" hex wrench, turn the drive bolt clockwise to thread it out of the shell plate. You must hold the shell plate from turning while doing this. A 3/16" hex wrench or small screwdriver through the plate in the depriming position works well.
- 3 If changing primer size, be sure to change the primer trough and primer punch before installing a new shell plate.

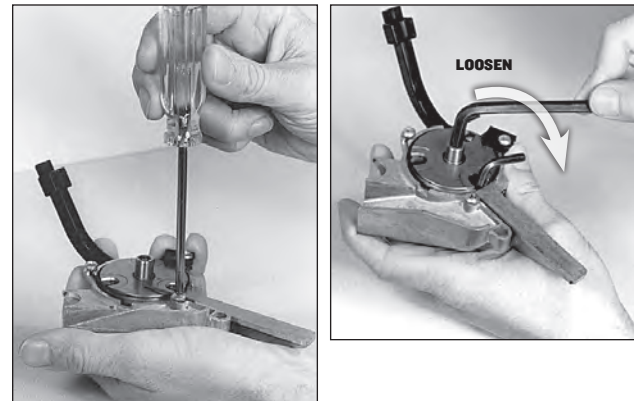

- 4 Be careful to not lose the 3/8" steel detent ball and spring. Also, be careful not to bend the spring fingers that hold the cases in the shell plate.
- 5 Reassemble the unit and readjust the zero index as explained under "Zero Adjustment" on next page.

DO NOT OVERTIGHTEN THE DRIVE BOLT. Turn until snug, using a single finger. DRIVE BOLT is easily user damaged by overtightening or turning in wrong direction.

5

SHELL PLATE PARTS LIST

When changing calibers that use a different primer size, we recommend changing the entire shell plate carrier. If caliber uses the same primer size, you can easily change just the shell plate.

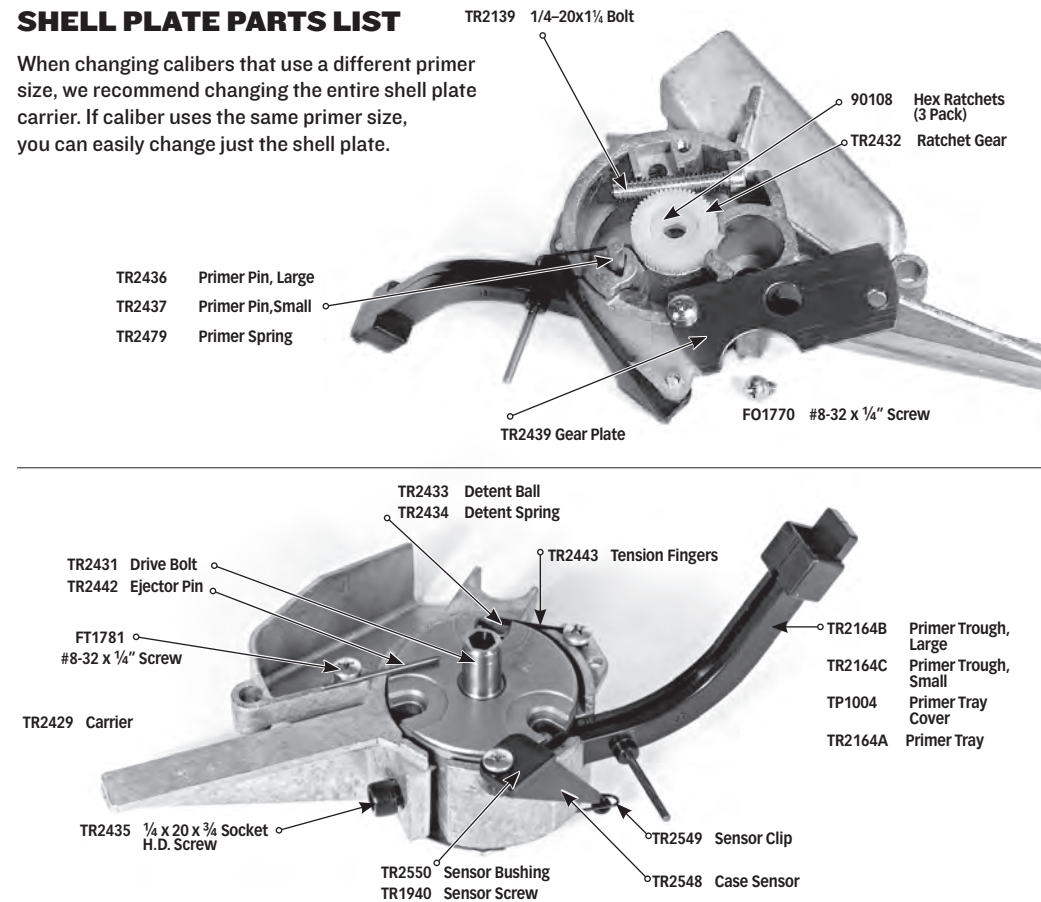

CARTRIDGE	SHELL PLATE NUMBER	SHELL PLATE ONLY	SHELL PLATE WITH CARRIER	SHELL SLIDER	COMPLETE CASE FEEDER	Z-BAR
32 SW Long & 32 HR						
380 Auto	4	90653	90646	small	90659	
38 SPC & 357 MAG						
357 MAG & 357 MAX	1	90651	90644	std.	90658	
45 ACP & 45 HP Italian	2	90652	90645	std.	90658	bent
9mm Luger	19	90669	90683	small	90659	
40 S&W	19	90669	90683	small	90658*	bent
10mm Auto	19	90669	90662	std.	90658	
41 Mag	9	90656	90649	std.	90658	
44 SP, 44 Mag, 45 Colt	11	90657	90650	std.	90658	
223, 222 REM & 7mm TCU	4	90653	90646	std.	90663	
7.62 x 39	12	90666	S.O. Lg. Prim.	std.	90658	
30M1	7A	90655	90648	std.	90663	
7mm BR	2	90652	S.O. Sm. Prim.	std.	90658	
32 Auto (ACP)	7B	90668	S.O. Sm. Prim.	std.	90659	
41 AE	19	90669	90683	std.	None avail.	
45 Auto Rim	13	90665	S.O. Lg. Prim.	std.	90658	bent
220 Russ, PPC	12	90666	S.O. Sm. Prim.	std.	90658	

S.O. = Special Order *Requires Purchase of Small Slider

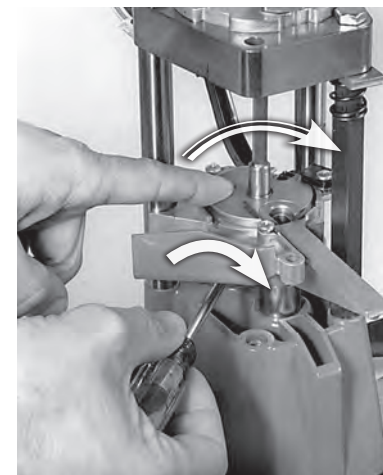

ZERO ADJUSTMENT FOR SHELL PLATE INDEXING

With the turret installed, raise and lower the shell plate carrier. If the shell plate does not index to the proper spot, turn the adjusting screw clockwise; the shell plate should move. If not—raise and lower the ram again to engage the ratchet. Keep turning until the shell plate snaps into place; then turn an additional 1/2 to 3/4 turn.

Confirm the zero adjust is set properly. With the carrier in the down position, try turning the shell plate clockwise; there should be no movement. If there is, rotate the zero adjust screw a fraction of a turn clockwise to remove all free play.

This need only be done once. If the shell plate gets out of adjustment because of a short stroke or jam, simply advance the shell plate by hand, not the adjusting screw.

KEEP YOUR PRESS WELL OILED AND IT WILL LAST A LIFETIME

6

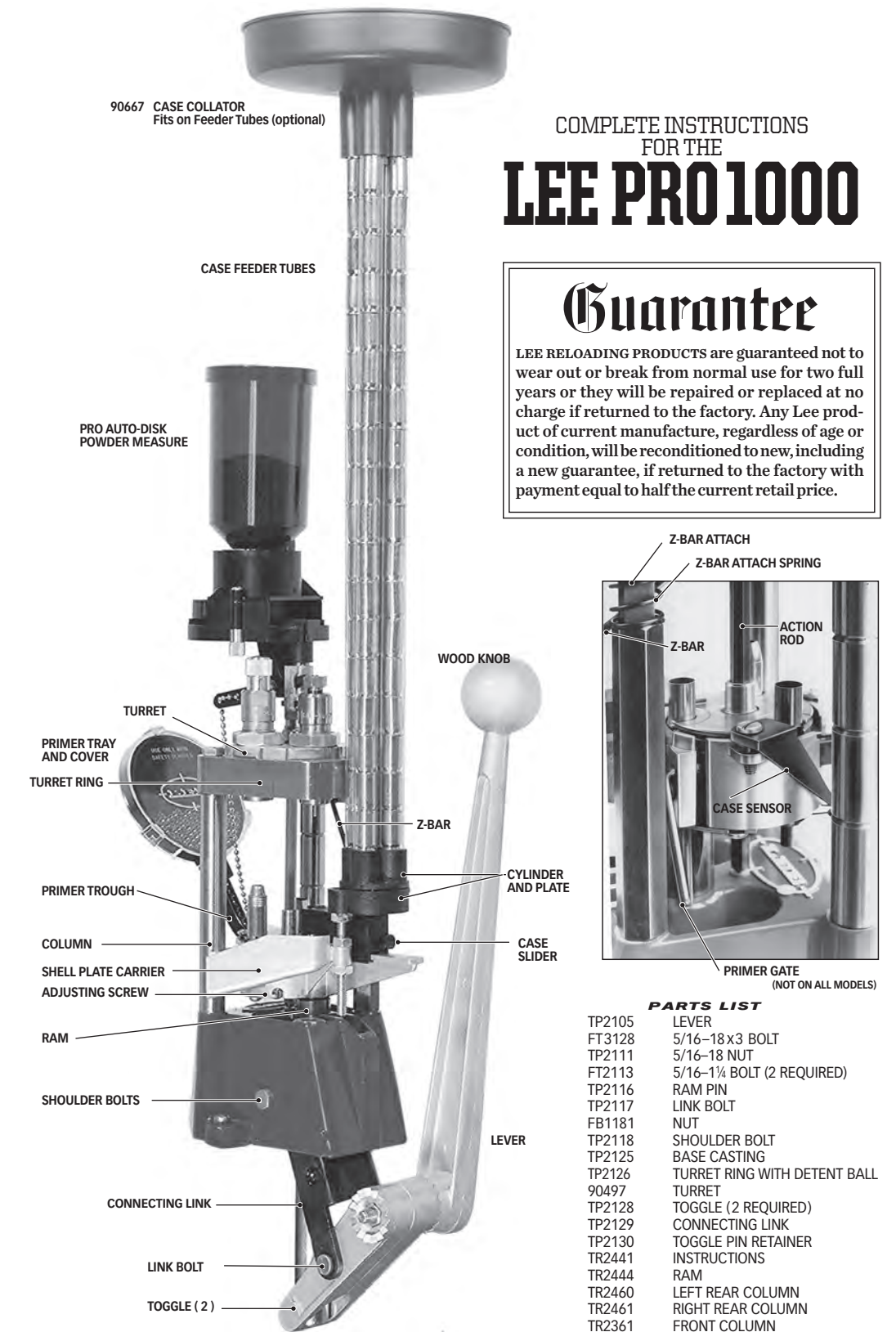

COMPLETE INSTRUCTIONS FOR THE LEE PRO 1000

Guarantee

LEE RELOADING PRODUCTS are guaranteed not to wear out or break from normal use for two full years or they will be repaired or replaced at no charge if returned to the factory. Any Lee product of current manufacture, regardless of age or condition, will be reconditioned to new, including a new guarantee, if returned to the factory with payment equal to half the current retail price.



PARTS LIST

TP2105	LEVER
FT3128	5/16-18x3 BOLT
TP2111	5/16-18 NUT
FT2113	5/16-1 1/4 BOLT (2 REQUIRED)
TP2116	RAM PIN
TP2117	LINK BOLT
FB1181	NUT
TP2118	SHOULDER BOLT
TP2125	BASE CASTING
TP2126	TURRET RING WITH DETENT BALL
90497	TURRET
TP2128	TOGGLE (2 REQUIRED)
TP2129	CONNECTING LINK
TP2130	TOGGLE PIN RETAINER
TR2441	INSTRUCTIONS
TR2444	RAM
TR2460	LEFT REAR COLUMN
TR2461	RIGHT REAR COLUMN
TR2361	FRONT COLUMN
TR2462	FRONT COLUMN SPACER
FT2463	5/16-18x2 1/4 BOLT
TR2452A	Z-BAR
TR2452B	Z-BAR Bent
TR2454	Z-BAR ATTACH
TR2455	Z-BAR ATTACH SPRING
TR2447	WOOD KNOB
TR2449A	CASE FEEDER CYLINDER & PLATE
TR2449B	CASE SLIDER
90661	CASE FEEDER TUBES (7 PACK)
TR2438	ACTION ROD

CAUTION

Ammunition reloading can be dangerous if done improperly and should not be attempted by persons not willing and able to read and follow instructions exactly. Children should not be permitted to reload ammunition without strict parental supervision. Always wear safety glasses when reloading and shooting. Ammunition loaded with these tools and data should only be used in modern guns in good condition. We do not accept responsibility for ammunition loaded with these tools or data as we have no control over the manufacture and storage of components or the loading procedure and techniques. Primers and gun powders, like gasoline and matches, can be dangerous if improperly handled or misused.

PRINTED IN U.S.A.

LEE

LEE PRECISION, INC. 4275 HWY. U HARTFORD WISCONSIN 53027

4.21.10

Lee Precision, Inc.

4984

CHECKED BY

TR2441 Pro1000 Instructions